

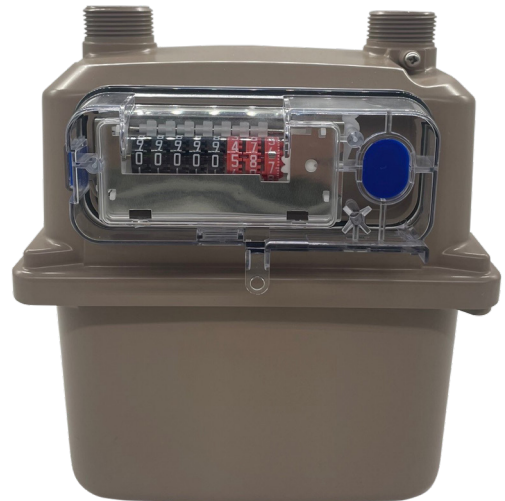

# U8

## Domestic & Residential Gas Meter

The U8 is a high-capacity domestic & residential gas meter from EDM's Gas Series. The U8 is rated to 8.0 m<sup>3</sup>/hr of gas @ 125 Pascal loss across the meter with a high level of accuracy due to its large cyclic capacity, radial valve covers and a magnetic drive which all combine to give superior accuracy retention and stability throughout the life of the meter.



### Key Features



PROVEN  
RELIABILITY

AMI

AMI READY



HIGH  
ACCURACY



ANTI TAMPER

# U8

## Domestic & Residential Gas Meter



### Standards and Compliance

- AS 4647
- EN 1359

### Capacity

- Gas: 8.0m<sup>3</sup>/hr (SG 0.64) @ 125 Pa loss
- Air: 6.4m<sup>3</sup>/hr @ 125 Pa loss

### Accuracy

- < ± 1.0% 1.2m<sup>3</sup>/hr to 6.4m<sup>3</sup>/hr
- < ± 3.0% @ Qmin

### Repeatability

- < 0.2% Typical

### Pressure Rating

- 25kPa (50kPa option available)

### Cyclic Capacity

- 2 Litre

### Proven Reliability

- Low oscillation and pressure loss characteristic minimises wear
- Large diaphragm area provides increased driving force
- Robust materials - resistant to environmental effects
- Magnetic index drive - superior leak tightness

### Tamper Resistant

- Security seal on body & index
- Tamper-proof magnetic index drive

### Environmental

- Temperature range: -10°C to +65°C
- Relative humidity: Up to 95%
- Corrosion resistant (AS 2331, 1000hr Salt Spray)
- UV resistant (AS 4647, EN 1359)
- Ingress protection: IP55

### Output

- Mechanical metric index XXXXX.XXX m<sup>3</sup>
- Pulse-ready inductive output: 1Pulse = 10L (optional)
- Tamper-proof Reed Switch Reading Head (optional)

### Physical Dimensions

- Connections: 1", 11tpi thread to BS746 with 6' centres
- Size: 234mm (W) x 252mm (H) x 205mm (D)
- Weight: Approx. 3.5kg
- Forward facing test-point

### Materials

- Body: DA401 Diecast with polyester powder coat
- Element: Tern-coated pressed steel body
- Bearings: Moulded acetal
- Diaphragm: Rubber moulded with polyester reinforcement
- Valves & Grids: phenolic
- Index Cover: UV stabilised polycarbonate
- Gears & Pinions: UV stabilised acetal
- Seals: Nitrile
- Links & Arms: Plated steel

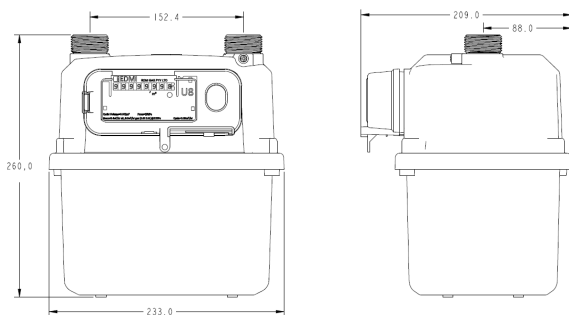
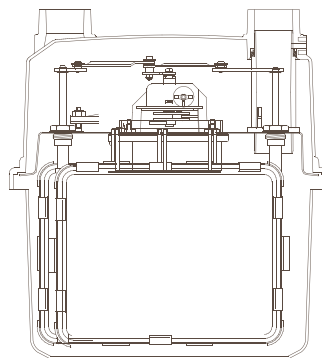
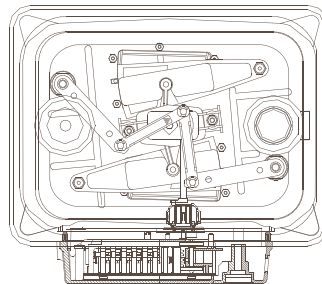

### EDMI Gas Pty Ltd

7 Fowler Road, Dandenong, Victoria,  
Australia 3175  
Tel: +613 9794 6000 Fax: +613 9706 0055  
Email: gassales@edmi.com.au  
support@edmi.com.au

### EDMI NZ Ltd

Level 1, 181 Wakefield St Wellington 6011  
New Zealand  
Tel: +64 4 801 4700  
Email: sales@edmi.co.nz  
support@edmi.co.nz

[www.edmi-meters.com](http://www.edmi-meters.com)

